



PMI: a PLM Approach for the Management of Geometrical and Dimensional Controls in Modern Industries

Francesco Ricci¹, Joel Sauza Bedolla², Javier Martinez Gomez³ and Paolo Chiabert⁴

¹Politecnico di Torino, francesco.ricci@polito.it

²Politecnico di Torino, joel.sauza@polito.it

³Universidad Industrial de Santander, javimar@uis.edu.co

⁴Politecnico di Torino, paolo.chiabert@polito.it

ABSTRACT

Design and verification represent the beginning and the end of product manufacturing: they respectively define the product characteristics and confirm their actual compliance. Design and verification communicate by means of tolerance callouts applied to product geometry. These have been traditionally transmitted through technical drawings. Their reading and interpretation is the starting point for manufacturing and metrology. However, this practice leads to poor communication, non-value-added operations with a high risk of errors and information loss, as well as poor correlation between design, manufacturing and verification phases. Product Manufacturing Information (PMI) solves these problems by facilitating a comprehensive 3D annotation environment that allows the association of component's geometrical tolerance directly to the 3D model. In this paper, the use of PMI is investigated and analyzed through a case study that highlights the main advantages, user's efforts, and improvement margins.

Keywords: design and verification, PMI, coordinate measuring machine (CMM), geometric tolerances.

1. INTRODUCTION

Geometric Dimensioning and Tolerancing (GD&T) is the technical language developed in the last few decades of engineering practice to control the dimension and geometry of mechanical components and guarantee their interchangeability. Despite having two slightly different ideological foundations in the ASME [1] or ISO [2] standards, GD&T defines a consistent framework that has been firmly established as the international standard for legal contracting. In particular, technical drawings have become the main instrument for managing product information as they contain standard views of the product including all the GD&T tolerances necessary for its manufacturing. As Fig. 1 shows, product data management was born and for a long time has been relegated to a two-dimensional space domain.

The advent of Computer-Aided technologies (CAx systems) moved drawings from hard copy support (film, vellum or paper) to digital form, allowing the development of Product Lifecycle Management (PLM) based on software Product Data Management (PDM) systems. Two-dimensional product

information was soon enhanced by the introduction of three-dimensional modeling and analysis systems but it still retains a dominant role as contracting documentation. However, despite its unchallenged legal value, the exchange of product information based only on drawings is no longer the most effective. On the contrary, it becomes a bottleneck that forces the different actors playing along the product lifecycle to recreate personal CAD models for their internal processes, spending time for non-value-added operations (model regeneration) with a high risk of errors and information loss (reading, interpretation and transmission of drawing information) as well as poor correlation between design, manufacturing and verification phases. The dashed line arrows in Fig. 1 show the complex path followed by product information when communication relies mainly on 2D drawings. Each arrow crossing from the 2D to the 3D domain often involves users' intervention (data interpretation and manual typesetting in the new system) that seriously encumber the integrity of product data.

The cutting edge advance in this direction is represented by the promising possibility of annotating

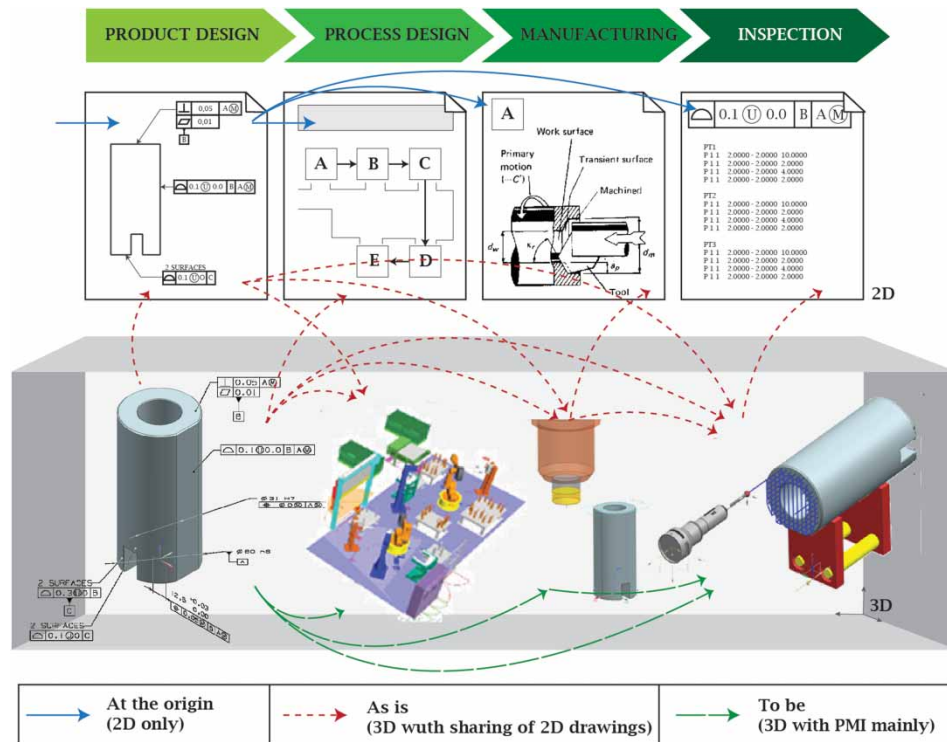

Fig. 1: The evolution of product data management. From the paper based communication (2D product studies) to pure digital 3D models.

product definition data directly to the digital 3D model. In most of the CAD systems this opportunity corresponds to a work environment named PMI (Product Manufacturing Information). PMI allows product teams to capture and associate a component's geometric tolerance directly to the 3D model. This information is then easily conveyed to downstream manufacturing applications (see Fig. 1). The tolerance definition is made once by designers and simply transferred to drafting, manufacturing and metrology.

At present, the capability of CAD systems in conveying product data through the 3D CAD model is considerable improving and remarkable improvements are being made at each new release. However, despite the improvements made, some important issues need to be addressed at both an operative and a higher level (mathematical foundations and portability).

A case study is presented in this paper which explores the main features of PMI-based product management, the great advantages that can be achieved, the efforts required, and the margins for further improvement.

2. PMI IN A 3D MODEL

PMI conveys in a 3D annotation environment all the information necessary for the proper manufacturing and verification of mechanical components; namely

the GD&T tolerances. However, given that GD&T, as introduced by the ASME Y14.5 [1], evolved in conformity with two-dimensional representation, some enhancements need to be accomplished in order to guarantee its effectiveness also in a three-dimensional environment.

ASME Y14.43 [3] provides the best practice for digital product definition addressing the critical issues related with the extension of GD&T annotation to a 3D environment. This standard defines exceptions and additional requirements to existing ASME standards for using product definition digital datasets or drawings in digital format. For example, if we consider a straightness requirement on the lines of a surface, according to ASME Y14.5, "a straightness tolerance is applied in the view where the elements to be controlled are represented by a straight line". In a 3D model the product visualization is no longer constrained by two-dimensional views and the application direction needs to be explicitly stated. ASME Y14.43 offers two possibility to clarify the directionality of two-dimensional tolerance zones: to direct it with a Represented Line Element (Fig. 2(a)) or by using an Ordinate Axis of the model coordinate system (Fig. 2(b)).

Concepts introduced by ASME Y14.43 are acknowledged at international level, with minor adaptations, by the ISO 16792 standard [4]. A brief review of the most relevant practices follows in this section.

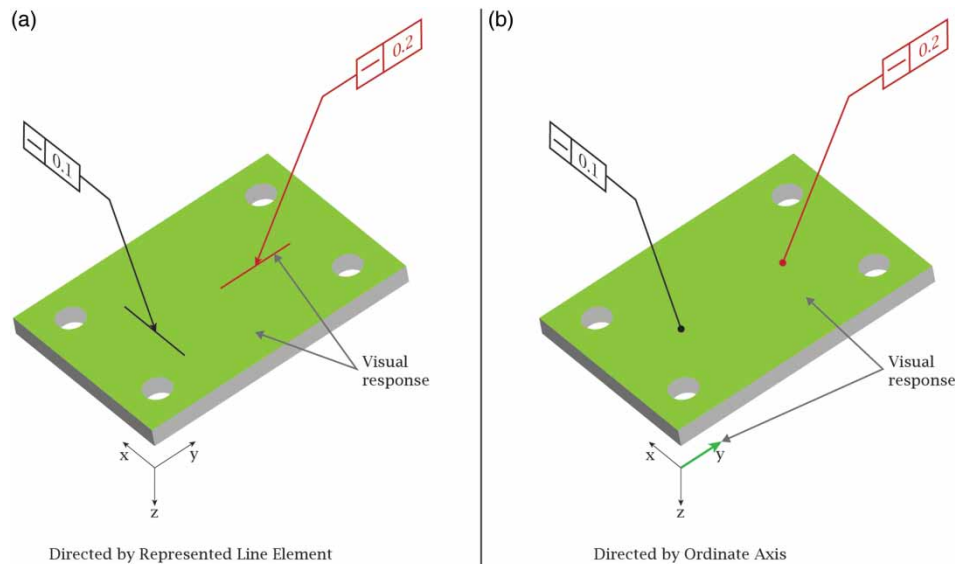

Fig. 2: Straightness; example of directionality specification for direction dependent tolerances [3].

2.1. Information to be Annotated on the Model

ASME Y14.41 supports two methods for preparing digital product definition data: *model only*, and *model and drawing* in digital format. In both cases, model geometry is considered the nominal geometry and only the information necessary for manufacturing shall be annotated; namely the direct limits or tolerance values on the intrinsic dimension of Features of Size (FOS), geometric tolerances (form, orientation and location), and surface finish requirements. For any purpose the CAD model may be used for, nominal dimensions are already embedded in it and there is no need to explicitly show them (as it was previously required by 2D technical drawings). If necessary, they can be extracted by queering the model geometry. Additional elements such as center marks, axes and median planes do not need to be represented any more since the geometry of the associated components is clearly represented by the 3D model.

With respect to NX 8, PMIs are generally annotated to the model after features have been modeled. In the particular case of tolerances on the intrinsic dimension of Features of Size (e.g. see the dimensional tolerance on the slot width in Fig. 3), PMI definition can be moved to the feature definition phase (still in the sketch environment). The advantage is that such defined dimension can be edited from the model view without re-entering the sketch environment. However, the PMI association has still to be manually refined.

2.2. Feature Association

Every PMI annotated on the model has to be associated to a target feature. In this way the tolerance semantics (namely the tolerance zone) is associated to the model nominal feature. If the tolerance is

correctly associated, the associated features should be highlighted in answer to the PMI query (see for example Fig. 3).

The leader line which graphically links PMI to the target feature is meant only to improve the model readability and has generally no effect on the associated features. Associated features can be inherited from another PMI only if the leader line aims at another fully defined PMI. For example (see datum features B and C in Fig. 3), if a datum feature is qualified with a geometric tolerance, and this tolerance is chosen as the terminating object for the leader line of datum feature symbol, the datum feature symbol inherits the associated features of the flatness tolerance.

If some PMI refer to more than one feature, all involved features shall be associated and an annotation shall be added, above or below the tolerance, stating the number of associated features in order to enable readers to understand the correct association without querying the model (see Fig. 3). Such annotation is actually out of the “feature control frame” and has no meaning for the CAD system; it is intended for improving model readability for human users only.

On the other hand, if more than one PMI refer to the same feature (see for example the geometric tolerances on the datum feature B in Fig. 3) particular care shall be dedicated to their definition. Particularly every PMI shall be independently defined and the different feature control frames shall be gathered into an associated group. A designer could be tempted to use the annotation environment provided besides the feature control frame definition (which usually allows the definition of supplementary tolerance lines too), but any information appended outside the feature control frame is intended for mere display purposes and the

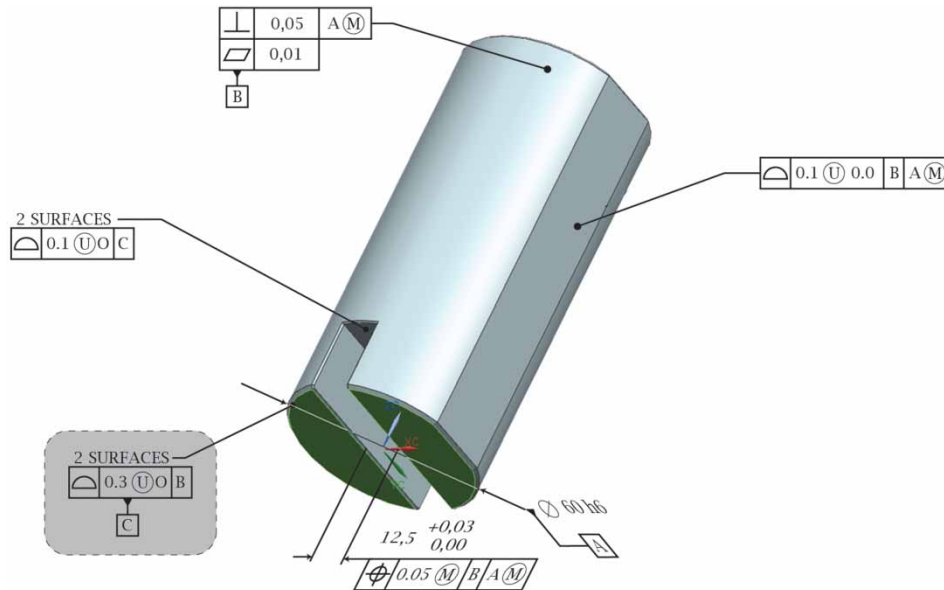

Fig. 3: Model only representation of the case study. Detail of a geometric tolerance query. Tolerance is associated to two features that, together, define the planar datum feature C.

tolerance semantics would not be associated to the feature.

2.3. Display Management

Given that product definition data can be prepared either according to the model only or model and drawing method, all PMI shall be annotated in one or more annotation planes and shall be clearly visible in any case. If the CAD system at hand does not support maintenance of annotation plane relative to the model, the model only method shall not be applied.

PMI can be generated in a model view and displayed in other views as derivative display instances. In this way they are defined once and displayed in each view with the most convenient orientation and graphical adjustment. For example, if the indicated element is a surface, the leader line shall terminate with a dot within the bounds of the surface (see Fig. 3). If the same feature is represented as a line element in orthographic view, the leader line shall terminate with an arrowhead indicating the represented line element (in conformance with the two-dimensional drawing rules).

3. INSPECTION PLANNING

Tolerances, either dimensional or geometrical, appended to a nominal model provide the Product Manufacturing Information. Such information is the driver for manufacturing choices and represents the quality target to be achieved. Verification (measurement) is the operation usually dedicated

to compliance check. When dealing with complex components and several different features to be verified, Coordinate Measuring Machine (CMM) is usually preferred to other instruments for its great versatility and the capability to measure nearly any geometry with a very high accuracy (the Maximum Permissible Error on the single point measurement is usually within the range of few micrometers).

Fig. 4 shows PMI lifecycle with respect to product design and verification phases. The reader notices that the “as is” and “to be” scenarios do not refer to the technology available at the state of the art, but respectively to the average scenario occurring in leading companies and the desired future scenario. Technology for realizing the “to be” scenario is still under development and not yet established. In this paper, an assessment of the “to be” scenario is performed against the “as is” scenario through a case study.

With reference to Fig. 4, the first three activities, in the area of product engineering, have been addressed in the previous section and refer to creation of digital product datasets. All information paths within the CAD environment are largely associative.

Analyzing the “as is” information path shown in Fig. 4, it can be noticed that several non associative operations are required for verification (process engineering area), if the product representation is based only on drawings. Verification process starts with the identification of every drawing annotation to be verified (Operation 4) and the definition of report documentation (Operation 5). Operation 4, also known as ballooning, consists of attaching progressive numerical labels to every annotation (dimensional

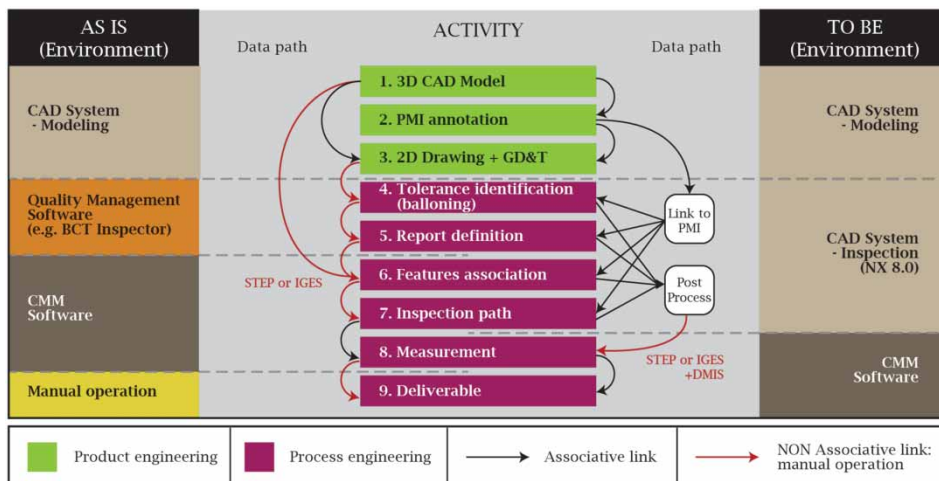

Fig. 4: Verification scenarios: main operations, paths of data exchange and software environments serving as platform.

and geometrical tolerances, surface finish requirements...). Then, in Operation 5, a spreadsheet is created that will make the report documentation. Particularly, it allocates a line to every balloon where verification outputs (measurement results and acceptance test outcome) will be resumed besides specification data. In most advanced scenarios ballooning and report generation operations are automated through quality management software. However the link is not associative as a modification to the input drawing, after output documents generation, does not affect the output documents.

According to measurement operations, these usually start from the above defined measurement report, two-dimensional drawings, and possibly a CAD model with the nominal geometry (surfaces only) imported in the CMM software through one of the available exchange interfaces (e.g. STEP or IGES). Then, starting from this material, process engineers can define the CMM part program through the following operations:

- **Operation 6 (Features association):** identification of features to be inspected and re-association of tolerances on the imported CAD model. At the state of the art no neutral exchange interface has proved to be able of transmitting PMI and maintaining associativity with the model surfaces. Tests have been performed by the authors to transmit different types of PMI (dimensional and geometrical tolerances, annotations, datum feature labels) with all available exchange formats and several Computer Aided Manufacturing (CAM) software. Portability was unacceptably poor.
- **Operation 7 (Inspection path):** for each feature to be inspected, a suitable part program is realized, which defines the probe inspection path.

This is, at any rate, a CAM operation where the machine tool is a CMM and tool is replaced by a sensor (either contact or contactless).

- **Operation 8 (Measurement):** features to be inspected are actually measured by running the prepared inspection paths on CMM. Portability of inspection paths on different CMMs is actually guaranteed by the Dimensional Measuring Interface Standard (DMIS).
- **Operation 9 (Deliverable):** measurement points extracted during previous operation are analyzed in order to assess the actual geometrical deviation. This is hence compared against the acceptance limits set by specification with the *acceptance test* [5]. If the assessed deviation is lower than the admitted error, the feature can be accepted. Otherwise it needs to be reworked, if possible, or the whole part must be discarded. Measurement results, along with the outcome of the acceptance test, are stored in the report documentation prepared at Operation 5.

According to the “to be” scenario depicted in the right part of Fig. 4, it can be easily noticed that most of operations is associative and can be performed on a common software platform. Particularly, with respect to the case study presented in this paper, Siemens NX 8.0 has been used both for product design (the Modeling module) and process design (the Inspection module). As a matter of fact, the only non associative link is represented by the interface between Siemens and the CMM software. However, non associativity of this link is easily overcome by the robustness of Post Processor and DMIS exchange interface, which together allow a trouble free transmission of CMM instructions and deliverable report documentation.

In the “to be” scenario, PMI is annotated directly on the 3D model following the recommendations

resumed in Section 2. If required, two-dimensional drawings can be easily obtained by adding the information necessary to comply with two-dimensional drawing rules (ASMEY 14.5): namely the nominal dimensions. However, following inspection phase does not need drawings and can rely entirely on the model only representation.

When the annotated 3D model is sent to the Inspection environment, PMI is not yet available. However, the “Link to PMI” button allows an easy inheritance of all information from the annotated 3D model. As soon as PMI is inherited, features to be inspected and associated tolerances are identified, created in the inspection file, and displayed, on query, on the 3D model. Particularly, an inspection path is generated automatically for each feature (if a probe has been selected) and a line is allocated in the measurement report for each tolerance. At this point minor revisions are required for process engineers before releasing the CMM part program.

Automatically generated CMM part programs consist, by default, of a nine points sampling grid. However, sampling grids can be easily customized thanks to the vectorial parameterization of points dataset definition. Regardless the adjustment on number of measurement points, for the case study presented here, the main required amendments were:

- Refinements on the tolerance zone definition: the unequally disposed modifier on profile tolerances was not recognized. Tolerances were treated as symmetric and had to be corrected in the Inspection environment.
- Simultaneous requirement on the pairs of features controlled by unequally disposed profile tolerances: a single feature was correctly associated to both pairs of coplanar surfaces shown in Fig. 4, but the system failed in generating the inspection path, which had to be defined manually. The problem seems to be related to the geometry of features making each pair, as it would not occur if the two surfaces have a rectangular perimeter.
- Adjustments of the probe tip angle for inspection of the datum FOS A, which was set horizontally in the machine setup.
- Reordering of the inspection paths to minimize the number of probe angle changes.
- Modification of entry and exit points of some inspection path (for some feature only) to avoid probe collisions. As a default, movement between the exit point of an inspection path and the entry point of the following one are linear interpolations between the coordinates of these points.

Inspection paths generated in this way can be easily deployed on any CMM using the available exchange

interfaces. Particularly inspection paths and measurement report can be transmitted through the DMIS exchange interface (using a Post Processor), while the inspection setup (part to be measured and eventually clamping tools) requires geometry exchange interfaces such as STEP or IGES.

Metrologist operating the CMM only needs to realize a “manual alignment”. He first adds a section to the part program, which allows for the manual alignment operation, and then drives the touch probe in exploring the part for correctly identifying its position and orientation within the CMM workspace. Measurement can then proceed in fully automatic mode, if virtual validation of the part program has been performed. Measurement results are analyzed by CMM software, according to the tolerances associated to each measured feature, and stored automatically in the report documentation.

4. PERFORMANCE ANALYSIS

Time required for the design and verification activities analyzed in Fig. 4 has been measured in several scenarios to compare the efficiency of different data paths (see Fig. 4). Filling color in the table cells is the same color used to identify the software environment in Fig. 4. Particularly, the same operator, which was very skilled in each of the different scenarios, was timed only with respect of practical operations. Time registered in Tab. 1 does not account for the product study, design and definition of geometrical tolerances, but only for time required in annotating and managing this information in the CAx system.

“As is” scenarios are characterized by a large time consumption for the verification phase. In the best case, where quality management software is used, 108 minutes are required to plan and perform the product geometrical verification. This time can be easily reduced of nearly 60% (down to 46 minutes) if design of verification operations is based on model annotated PMI.

If the observation is limited at modeling activity, the advantage of model only product data representation is not evident in mere terms of time saving. As a matter of fact, some activity such as annotation of nominal dimensions is avoided in the “to be” scenario but the time saved is spent for addressing display refinements in the 3D environment (particularly if the model and drawing method is required). Some time saving is achieved already at the modeling stage if model only exchange is chosen: 43 minutes are necessary against the 59 required for model and drawing presentation or the 52 minutes required by the classical drawing based data exchange. Advantages provided by PMI for the management of geometrical and dimensional controls would be much greater for components more complex than the case study presented here.

	3D modeling					Design Time	Verification										Verification Time	Total	
	Centerlines and axis	Sections and orthographic views	Tolerances annotation	Quotation of nominal dimensions	View display adjustments		Tolerance identification	Report definition	Feature generation	Tolerance association	Inspection path generation	Virtual validation of inspection path	Part program generation	Alignment on CMM	Measurement	Deliverable			
(Without BCT) As is	20	1	6	8	15	1	51	2	13	6	18	35	1	0	8	30	10	123	174
(With BCT) As is	20	1	6	8	15	1	51	0	0.5	6	18	35	1	0	8	30	10	108.5	159.5
(Model & Drawing) To be	20	1	2	15	15	6	59	0	0	0.5	1	5	1	0.5	8	30	0	46	105
(Model only) To be	20	0	2	15	0	6	43	0	0	0.5	1	5	1	0.5	8	30	0	46	89

Tab. 1: Performance analysis of verification scenarios depicted in Fig. 4. Time required by each operation is expressed in minutes. Some operation has been decomposed in more detailed operations to increase the level of detail. Background color of cells follows Fig. 4 colors.

PMI advantages would be even greater if the ISO technical language for Geometrical Product Specification and Verification (GPS) was fully defined and available as a standard. As a matter of fact, the tolerance callout would be much larger and would carry all the information necessary to completely define the verification operator: number of points to be measured, filter to be used, and association criterion for analyzing the data. Regardless time saving during inspection paths design, GPS language would improve also the efficiency of product data management allowing the identification of uncertainty (which always implies cost) sources and specific intervention where this becomes unacceptably large.

5. CONCLUSIONS

The analysis presented in this paper highlights that, if the model and drawing system is used, the designer is required to make a slighter harder effort for the annotation of PMI. Each tolerance has to be carefully associated to the target feature and its display has to be adjusted in the required model views. However, once PMI has been associated, tolerances can easily be imported into the drawing environment too and are available for later use in manufacturing and inspection environments.

PMI guarantees a fully parametric and associative product data definition down to the inspection paths generation. As a matter of fact, if inspection paths are defined parametrically with respect to the measurand feature (e.g. inspection paths generated automatically), these regenerate correctly if some model parameter (e.g. diameter of a hole/cylinder) is

changed. This would be impossible if the inspection path was defined in a software environment other than the CAD one, as there is not yet an exchange interface able to carry PMI together with the model geometry.

The definition of an exchange interface for transmission of PMI between different CAx systems would solve the problem of portability and provide a burst for PMI diffusion. Further improvements could also be achieved, at a higher level, in the mathematical definition of the technical language moving toward the ISO-GPS framework, which extends GD&T to an operation-based fully-mathematically-defined language.

ACKNOWLEDGEMENTS

This research has been carried out with software made available by the PACE program and with the sponsorship of Fiat Group Automobiles. Authors thank engineers from Fiat and GM for their help in understanding the state of the art and identifying critical issues for the use of PMI.

REFERENCES

- [1] ASME Y 14.5 (2009) Dimensioning and Tolerancing - Engineering Drawing and Related Documentation Practices.
- [2] ISO 1101 (2004) Geometrical product specifications (GPS) - Geometrical tolerancing - Tolerances of form, orientation, location and run-out. ISO, Geneva.

- [3] ASME Y 14.41 (2003) Digital Product Definition Data Practices - Engineering Drawing and Related Documentation Practices.
- [4] ISO 16792 (2006) Technical product documentation - Digital product definition data practices. ISO, Geneva.
- [5] ISO 14253-1 (1999) Geometrical product specifications (GPS) - Inspection by measurement of workpieces and measuring equipment - Part 1: Decision rules for proving conformance or non-conformance with specifications. ISO, Geneva.