



Computer-Aided Traditional Art Design Based on Artificial Intelligence and Human-Computer Interaction

Tanqiu Wang¹²  and Dan Wu³⁴ 

¹Art School, Zhengzhou Technology and Business University, Zhengzhou 451400, China, 20090036@ztbu.edu.cn

²School of Education, Stamford International University, Bangkok 999003, Thailand, 20090036@ztbu.edu.cn

³School of Education, Stamford International University, Bangkok 999003, Thailand, 20090225@ztbu.edu.cn

⁴Academic Affairs Division, Zhengzhou Technology and Business University, Zhengzhou 451400, China, 20090225@ztbu.edu.cn

Corresponding author: Tanqiu Wang, 20090036@ztbu.edu.cn

Abstract. Computer-aided art design has become a brand-new art design expression means with excellent development prospects, which provides a brand-new art expression form for designers and brings profound changes in art design aesthetics and art design thinking. With the help of modern artificial intelligence (AI), the quality and efficiency of modern art computer-aided design (CAD) can be greatly improved, which is the main realistic form and important development direction of modern art design. In order to realize the innovation of traditional art design methods and improve the application of CAD technology in art design, this article puts forward an art image enhancement algorithm based on deep belief network (DBN), and extends the design optimization-driven deep learning (DL) framework with task-specific algorithm to enhance the interactive experience in art design process. The results show that this method can well preserve the local structural information in the image. Contrast and stereoscopic enhancement; It embodies the characteristics of optimal scale selection. The effectiveness and outstanding performance of the proposed art image enhancement algorithm are verified by experiments.

Keywords: Artificial Intelligence; Man-Machine Interaction; CAD; Artistic Design

DOI: <https://doi.org/10.14733/cadaps.2024.S7.59-73>

1 INTRODUCTION

The comprehensive application of AI technology and interactive art of new media is the combination of technology and art. The interactive art of new media expressed by AI technology is mainly the interaction between computers and people, so the interactive art of new media under

AI is mainly the human-computer interaction (HCI) technology. In the context of interactive art, the creative possibilities of artificial intelligence assisted speech to image synthesis are very broad. This technology can provide viewers with a more intuitive and vivid artistic experience by converting speech into images. Canet and Guljajeva [1] can use artificial intelligence technology to synthesize the audience's voice into images in real-time, creating real-time interactive art works. For example, the audience can participate in the creation of art works by controlling the shape, color, motion, etc. of images through voice control. Through artificial intelligence technology, the emotional expression of the audience can be transformed into images, thereby better understanding and conveying emotions. Through artificial intelligence technology, speech and actions in virtual reality can be converted into images, providing viewers with a more realistic and vivid virtual reality experience. As one of the practice bases, the core of interactive art is to create more novel experiences. The emergence of AI has changed the relationship between people and equipment, people and products, from tangible to intangible, realized the further extension of product interaction design in breadth and dimension, and changed the way of product HCI design. In the context of new media, the interactive design of museum display systems is an innovative design method that enhances the interaction and participation between the audience and the display content through the use of new media technology and interactive design methods. This design method can make the audience more actively participate in the display, improving the effectiveness and attractiveness of the display. Cheng [2] participated in the interactive design of a museum display system, which adopts new media technology and interactive design methods to achieve interaction and participation in the display system. Multiple interactive screens are set up in the display system, and the audience can interact and participate in the display content by touching the screen or using gestures. It uses virtual reality technology to create a virtual environment, allowing the audience to immerse themselves in the display content and enhance their sense of participation through virtual interactive links. Use facial recognition technology to identify and track audiences, providing personalized display content and interactive links for each audience, and improving the pertinence and effectiveness of the display. Computer-aided art design has been widely valued and applied because of its advantages of accuracy, authenticity, convenience for preservation and modification, and ability to inspire designers' creative inspiration. Because CAD has incomparable advantages in the field of art design, it is increasingly introduced into the field of art design. The essence of interactive art design is the communication between people, works and equipment, and if you want to play the application value of AI and integrate it into interactive art design, you must follow the principle of humanization. Applying AI and CAD technology to traditional art interactive design can effectively enhance the HCI ability of art design, which plays a very positive role in improving the effect of art works and people's sensory experience. Kinect is a deep learning-based computer vision technology that can capture and analyze human gestures and movements in real-time. It obtains human body data through infrared and RGB cameras, and then uses complex algorithms for data processing and recognition. Chenyi and Choi [3] are based on Kinect technology, allowing new media artists to create interactive devices that change the way art is displayed by recognizing and tracking human gestures. For example, controlling the playback, pausing, or changing colors, shapes, etc. of art works through gestures. In new media art, artists can combine the five elements with Kinect technology to control and display these elements through human gestures. Through the combination of Kinect and the Five Elements, new media artists can transform abstract concepts into concrete works of art. At the same time, the technology of imaging science can also enhance the visual effects of art and create stunning visual experiences. In summary, the human gesture and five elements of Kinect based interactive devices are an innovative technology that closely combines art and imaging science. It provides a new creative approach for new media artists to capture and analyze human gestures and movements in real-time, thereby changing the way art is displayed and creating an amazing visual experience. The application of AI driven interactive learning method in college art Design education is an innovative education method, which can provide students with more personalized and independent learning experience, thus improving students' learning effect and creativity. Fan and Li [4] analyze and evaluate students through AI

technology, understand each student's Learning styles, interests and advantages, and then develop personalized education plans for them to help students better master knowledge and skills. Through an intelligent tutoring system, students can learn anytime and anywhere. The system can provide personalized learning suggestions and feedback based on students' learning progress and performance, helping them better master knowledge and skills. Through interactive learning methods, students can interact with the learning content to better understand and master knowledge. For example, students can design their own Digital art works through virtual reality technology, and interact and modify with Digital art works through human-computer interaction technology. Through artificial intelligence technology, analyze and evaluate students' learning data to understand their learning situation and problems, and provide corresponding feedback and suggestions to help students better master knowledge and skills.

Computer aided molecular product process design under property uncertainty is an optimization strategy based on Monte Carlo. Frutiger et al. [5] aims to solve the problem of property uncertainty in the process of Computer-aided design. This strategy is mainly through the establishment of an uncertainty model, and the use of Monte Carlo method to carry out probability statistics on the model, so as to obtain the optimal solution. In the specific implementation process, the strategy first needs to fit the probability distribution of design variables, usually using Normal distribution or uniform distribution. Then, Monte Carlo method is used to randomly sample the model, generate a series of possible molecular structures, and then calculate the corresponding properties. By repeated sampling and calculation, the probability distribution of properties can be obtained to determine the optimal solution. HCI art represented by interactive design is a new artistic expression, which can not only realize normal HCI, but also bring good artistic experience to users through various senses and psychology of human body. With the help of modern computer control technology, the quality and efficiency of modern art design can be greatly improved, which is the main realistic form and important development direction of modern art design. CAD means update the original artistic design expression, which provides designers with sufficient, efficient and all-round technical means and creates visual effects that traditional design can't match. The development and application of AI technology has injected new vitality into art CAD design and improved the level and efficiency of art CAD design as never before. From the perspective of computer application system, AI technology mainly studies and manufactures intelligent machines or intelligent systems to simulate human intelligent behavior and activity ability. Driven by AI, this article puts forward an image enhancement algorithm of art design based on DBN to improve the HCI experience of art design and realize the innovation of traditional art design based on CAD.

If designers want to better integrate AI with interactive art design, they should pay more attention to humanized interactive experiences. The traditional method of enhancing the quality of art works is realized by calculating the dot gain value of art works. Although it can enhance the color reproducibility, it can't determine the best field density, which leads to the phenomenon of ghosting and deformation of art works. This article studies the application of AI and HCI technology in art CAD design, and makes the following innovations:

(1) In the study, the gray value of the image is transformed into a difference representation matrix, which realizes the expansion of the low gray area and the compression of the high gray area, and enhances the contrast of the image; Then, the difference feature matrix is de-averaged, normalized and thinned. Finally, the sparse difference matrix is input into the DBN network.

(2) From the perspective of optimization, this article regards the solution of the deep network as the descending direction to speed up the search of the target solution, and defines the discrimination and correction mechanism based on the optimization theory to ensure that the solution obtained through the deep network is always satisfied in the feasible region, and finally the target solution that can converge to the critical point can be obtained.

In this article, the model of art image enhancement and interactive optimization is constructed by combining AI and CAD, and the art image enhancement algorithm based on DBN is proposed.

Experiments show that the algorithm is practical in traditional art interactive design. Finally, the results of this article and the future research direction are summarized.

2 RELATED WORK

The adaptive retina mechanism is an image enhancement technique that can adaptively adjust the display effect based on the brightness and contrast of the image, making the image clearer and more realistic when viewed by the human eye. In underwater image enhancement, due to the refraction and scattering of light in the underwater environment, images often exhibit blurring, distortion, color deviation, and other issues. Gao et al. [6] performed image processing using adaptive retinal mechanism for underwater image enhancement. According to the principle of adaptive retina mechanism, appropriate high pass filter coefficients are calculated and the image is filtered to enhance the details and contours of the image. When using adaptive retina mechanism for image enhancement, adjustments and optimizations need to be made based on specific images and environments to achieve the best results. Real time interactive art using particle systems is a new form of art that combines technology and art. This art form uses particle system and computer graphics technology to create dynamic and interactive art works. Jeon [7] uses computer graphics technology to create high-quality images and present them on the screen. In real-time interactive art, computer graphics technology can be used to create dynamic visual effects, such as particle system rendering and animation. Real time interactive art typically uses various interactive technologies, such as sensors, cameras, touch screens, etc., to allow the audience to interact with the artwork. During the interaction process, the computer can respond to the audience's actions in real-time and change the display method and effect of artistic works. In short, real-time interactive art using particle systems is a new form of art that combines technology and art. It uses particle systems, computer graphics and interactive technology to create dynamic and interactive works of art, bringing new vision and experience to the audience. Computer-aided design software can add lighting, materials and other effects to make the design effect more realistic, and can also simulate the effect of natural light in a virtual environment. Computer-aided design software can automatically generate plans, sections, construction drawings, etc., making the design more accurate and detailed. In the teaching of environmental art design, the application of Computer-aided design software can help students better understand the design concept and skills, and also can better master the operation of design software. Through Computer-aided design software, Jin and Yang [8] students can more freely play their creativity and imagination, and also more accurately express their design ideas. In a word, the application of Computer-aided design software in the teaching of environmental art design has very high value. It can improve the quality and efficiency of teaching, and also help students better master design skills, laying a solid foundation for future design work. The Digital art design system based on Big data technology and interactive virtual technology is an innovative design tool, which can help designers and artists better design and create Digital art. Li [9] used Big data technology and interactive virtual technology to present a large amount of data to designers and artists in an intuitive and vivid way through Big data technology to help them better understand and analyze data, so as to carry out better Digital art design. The use of virtual reality technology to create a virtual environment allows designers and artists to design and create Digital art in a virtual environment, so as to better understand and feel the design effect. Through human-computer interaction technology, designers and artists can interact with Digital art works through interaction, so as to better understand and feel the charm of Digital art works. In short, the Digital art design system based on big data technology and interactive virtual technology is an innovative design tool. It can help designers and artists better design and create Digital art, and bring more rich and vivid Digital art experience to designers and artists. The applicability of 3D factory simulation software in computer-aided Participatory design of industrial workplaces and processes is very high. This software can provide a very realistic and intuitive environment, allowing designers, engineers, managers, and other relevant personnel to better understand and design factory processes. Pelliccia et al. [10] used 3D simulation software to simulate actual factory

environments and processes in a virtual environment. To better understand and evaluate the impact of various design and layout choices on practical operations. The interactivity of this software can also enable multiple participants to collaborate in design and evaluation. In addition, 3D simulation software can usually be integrated with other Computer-aided design tools, such as CAD software and simulation tools, so that all aspects of design and production can be considered more comprehensively.

Artists can reveal through their works how personal data is collected, analyzed, and utilized, as well as how this data affects our lives and society. Stark and Crawford [11] create works of art by using personal data. This has sparked people's attention and reflection on data privacy. Artists can use data to present statistical information and reveal the biases and injustices that exist in society. For example, by using artificial intelligence technology to generate artworks, artists can reveal how artificial intelligence amplifies social biases and triggers attention and reflection on data biases. Artists can use data to present issues of power and monitoring, thereby revealing the control and utilization of data by governments and enterprises in modern society. For example, by using public data to create art works, artists can reveal how governments and businesses use data to monitor and control people's behavior and speech. Wang and Cai [12] analyzed the application of AI in 6G IoT communication in interactive Installation artwork. The 6G Internet of Things communication application of AI in interactive Installation artwork is a cutting-edge technology trend. The 6G Internet of Things communication technology provides more efficient and intelligent data transmission and processing capabilities for interactive Installation artwork, enabling art works to interact with audiences in a more real-time and vivid manner. Artificial intelligence technology can process and analyze the collected data, extract useful information, and provide real-time feedback and control. For example, machine learning algorithms can be used to learn audience behavior data, thereby adjusting the display method and effect of artistic works in real-time. 6G Internet of Things communication technology can provide high-speed and low latency communication capabilities, allowing viewers to interact more real-time and vividly with art works. For example, viewers can interact through mobile apps or smart devices, and art works can be adjusted and fed back in real-time based on their actions. In a word, the application of artificial intelligence in the 6G Internet of Things communication in interactive Installation artwork is a cutting-edge technology trend, which can provide more efficient and intelligent data processing and interaction capabilities for artistic works, and bring more rich and vivid artistic experience to the audience. The weakly supervised road network extraction based on remote sensing image graffiti annotation and adversarial learning is a road extraction method that combines image processing and machine learning techniques. Yuan et al. [13] used graffiti tools to annotate remote sensing images and mark the road network that needs to be extracted. This annotation method can quickly and accurately label the road network without requiring too much prior knowledge. It establishes an adversarial model that includes a generator and a discriminator. The generator is used to generate pseudo images similar to real images, while the discriminator is used to distinguish between real and pseudo images. Weak Supervised learning is carried out using graffiti labeled images, that is, only part of the labeled information is used for training.

During this process, the generator continuously generates pseudo images that are similar to real images, while the discriminator continuously optimizes its own model to better distinguish between real and pseudo images. After adversarial training, the generator can generate pseudo road networks similar to real road networks. By further processing the pseudo road network, real road networks can be extracted. The application of space augmented reality technology in Computer-aided design and computer graphics, such as virtual assembly, digital design, visualization, etc. The challenges and future development trends of spatial augmented reality technology, such as hardware device limitations, optimization of interaction methods, and the possibility of large-scale applications. Yuan et al. [14] aims to comprehensively introduce the research and application of human-computer interaction technology in spatial augmented reality in the field of Computer-aided design and computer graphics. Provide reference and guidance for research and practice in related fields. The new media Interaction design visualization system based on AI technology is a new design tool that combines AI technology and visualization

technology. This system can help designers and developers to carry out new media Interaction design more efficiently, and can also provide end users with more intuitive and vivid interactive experience. Zhang [15] uses AI technology for data analysis and learning to automatically generate new media Interaction design schemes and models. At the same time, the system can also present design solutions to designers and end users in a more intuitive and vivid manner through visualization technology. In addition, this system can also be combined with other advanced technologies, such as virtual reality technology, augmented reality technology, etc., to provide a richer and more diverse interactive experience. For example, designers can use virtual reality technology for comprehensive visual design, and end users can interact and experience in real-time through augmented reality technology. Cang Jie's poetry is an artistic experience of semantic human-computer reality interaction, which combines the latest achievements of American computer graphics and interaction technology. This art form uses Natural language processing technology and artificial intelligence algorithms to analyze and present the deep meaning of poetry. At the same time, through human-computer interaction, the audience can participate in the creation and interpretation of poetry. Zhang et al. [16] uses Natural language processing technology and artificial intelligence algorithm to perform semantic analysis and reasoning on the input poetry, and extract the deep meaning and emotional tendency of poetry. Viewers can interact with the system through human-computer interaction and participate in the process of poetry creation and interpretation. Viewers can interact with the system by inputting natural language or through interactive methods such as gestures and sounds. The system will generate corresponding poetry texts based on the audience's input. The system uses computer graphics technology to present the parsed semantic information and emotional tendencies of poetry to the audience in a Visualization way, so as to enhance the audience's understanding and experience of poetry.

3 ART IMAGE ENHANCEMENT AND INTERACTIVE OPTIMIZATION MODEL CONSTRUCTION

3.1 The Integration of New Media Interactive Art and Traditional Art Design Driven by AI

User information transmission scene is the core of new media interactive art expression scene, which is mainly responsible for users' consultation and understanding of new media interactive art, and can help customers to be more familiar with the expression process of new media interactive art and the service concept in the scene. The extraction of visual elements can be directly extracted by human vision without complicated procedures. Visual elements can include text, images, colors, etc. Image is a new language of visual elements, which can overcome language barriers and space barriers and bring more intuitive expressions to visual elements. In the traditional design field, because the main material used is paper, it will affect the whole body when modifying. Some minor mistakes may lead to the need to re-create drawings, sculptures and other works, which undoubtedly increases the creative workload. However, if the computer is used to carry out related design work, the troubles caused by related problems can be avoided. Designers can directly replace, scale, rotate or even delete the parts that need to be modified, and can see the actual effect of the modification in real time, so that the modification scheme can be adjusted quickly.

The new media interactive art push scenario is mainly responsible for pushing new media interactive art business messages to users, contacting different kinds of information concepts in the user information transmission scenario, and pushing corresponding interactive art services for users. Through CAD, designers can also store information such as color scheme and hue, and call it up directly when needed. Compared with the traditional hand-drawn operation, this operation is undoubtedly a great progress, which can save designers a lot of time and improve work efficiency. The aesthetic feeling of sound can directly bring people a certain sense of experience. In the process of sound element extraction of good new media interactive art, complexity calculation is

applied to eliminate the interference factors in sound, and the selection and configuration of sound factors are interactively calculated, so that sound processing, sound processing and music background processing can be carefully screened by complexity calculation.

AI is a subject that mainly studies the simulation of some intelligent behaviors and thinking processes of people by computers. Its main contents include the principles of computer intelligence and the growth of computers similar to human brain intelligence, so that computers can reach higher standards and higher-level applications. HCI elements mainly include control elements and interactive artistic expression navigation. The HCI elements extracted by complexity calculation have certain characteristics such as interpretability, consistency, uniqueness and common sense, which greatly facilitates the user's operating experience and enhances the user's understanding of interactive art. Through CAD, designers can realize the visual effects of many traditional visual media. Art designers can not only realize these artistic effects alone, but also combine them.

3.2 Art Image Enhancement Algorithm Based on DBN

For the tasks of image denoising and image inpainting, the depth image prior can directly use the mean square error loss function between the output image and the distorted image to achieve certain results. However, for distortions such as image blurring, low illumination and image fogging, it is not only possible to rely on the inherent prior of the image, but also to determine the prior of the distortion to construct the corresponding loss function according to the distortion model. In this article, a concept of difference based on fuzzy membership function is introduced to transform the gray matrix and sparse it, and then an improved DBN algorithm based on difference sparseness is proposed.

In the case of unknown distortion type and degree close to the real scene, it is difficult to confirm the appropriate loss function for reconstructing a clear image in depth image a priori. Therefore, it is proposed to predict the prior of distortion through the input distorted image to determine a more accurate distortion model to constrain the reconstructed image. The DBN network structure of art image enhancement is shown in Figure 1.

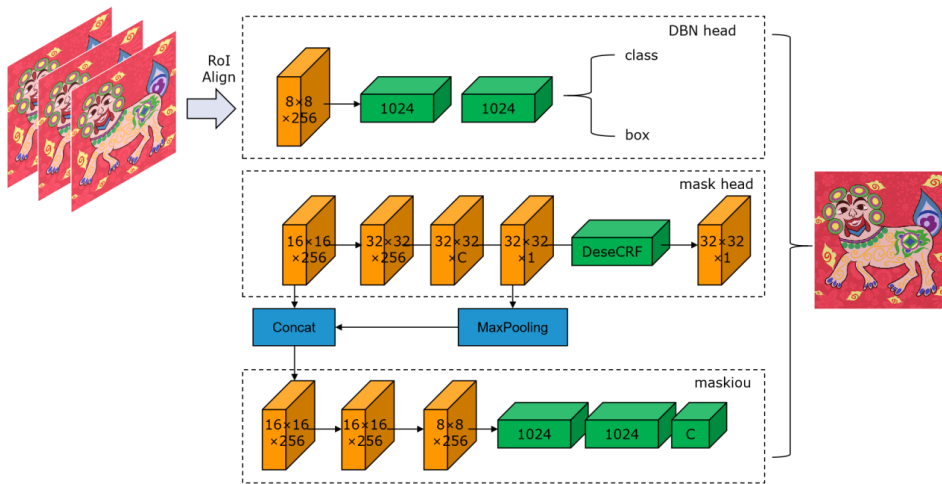

Figure 1: DBN structure of art image enhancement.

In the generator part, the mean and variance of the latent space color information Z_k extracted from the original color image Y_k are added, and then the black-and-white image X_k and the resampled Z_k are sent to the generator at the same time to get the generated image.

According to the boundary, the radius a, b, c and the center point of the ellipsoid in three dimensions can be obtained:

$$O = (x_0, y_0, z_0) \quad (1)$$

Each point in the area can be parameterized by the following expression:

$$\begin{aligned} x &= x_0 + a \cos \theta \sin \varphi \\ y &= y_0 + b \sin \theta \sin \varphi \\ z &= z_0 + c \cos \varphi \end{aligned} \quad (2)$$

After the boundary is determined, the deformation coefficient ω of this area can be obtained according to the result compared with the standard deviation of the average art image position, and the new vertex position can be obtained by calculating each characteristic vertex in the area with the following expression:

$$v' = o + \gamma \omega \lambda(r)(v - o) \quad (3)$$

Where v represents the original vertex position, v' is the new position after deformation, and r is the radius of the region. γ is the proportional factor of user interaction control.

At present, the performance of DL-based enhancement algorithm in real scenes is still limited, and there are two reasons for this problem. On the one hand, it is easy to encounter the mixed superposition of multiple distortions in the real scene, and it is difficult for the enhancement model based on single distortion to deal with the mixed multiple distortions, so it is necessary to study and design a model that can better deal with the mixed multiple distortions, which increases the difficulty of the task. Distortion prior network predicts the type and level of distortion contained in the image through classification modeling, and then superimposes it on the restoration result of image prior network, and calculates the loss function with the original distorted image to update the parameters of image prior network. The operation flow of DBN model is shown in Figure 2.

The prior of depth image will be used to extract the intrinsic content of distorted image and generate clear image from random noise. Distortion prior constrains the generated clear image by learning image degradation distortion. In the network structure, the depth image prior network adopts a generating network, which inputs a random noise and outputs the expected clear image. In the learning process, all the image prior networks corresponding to the samples of the test set are loaded into the video memory, and then randomly sampled from them to form a false sample combination. At the same time, some paired training data sets are used, and the image prior network is also used to enhance this part of the distorted image online as false samples, and then the corresponding clear samples are taken as true samples, which are also sent to the decider by random sampling.

Based on the labeling information, the sum of the correlation matrices of all images is taken as the correlation matrix of the whole data set, where N represents the number of training images. The correlation matrix can reflect the correlation of various physiological and anatomical structures in the data set from a macro perspective. Therefore, the correlation matrix CM is expressed as:

$$CM = \sum_{i=0}^N CM_i \quad (4)$$

Because the conditional probability between some objects in the matrix is small, these data are not common and will become noise, which will not only affect the overall data distribution, but also affect the convergence of the model. In order to filter out these noises, this article uses a threshold ε to binarize the matrix CM :

$$CM_{ij} = \begin{cases} 0, & P_{ij} \leq \varepsilon \\ 1, & P_{ij} > \varepsilon \end{cases} \quad \varepsilon \in [0,1] \quad (5)$$

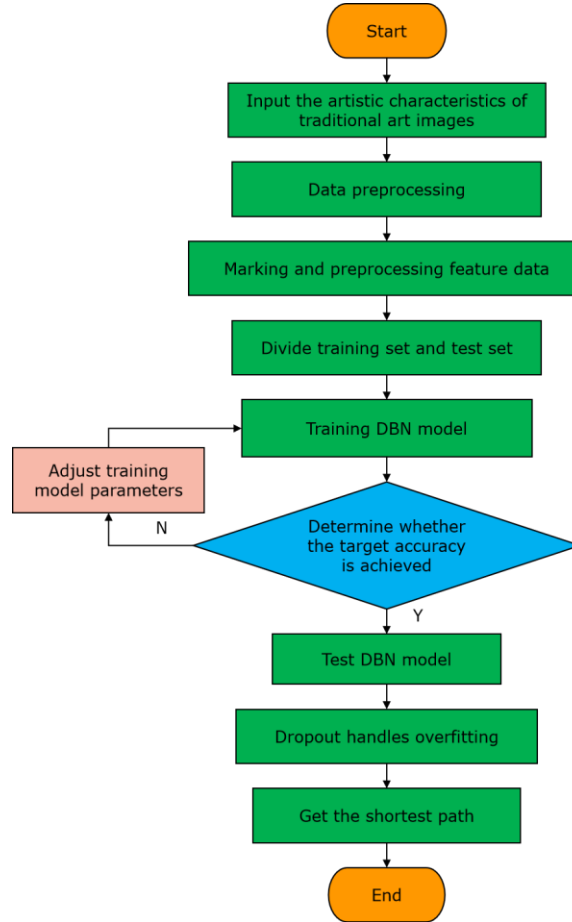

Figure 2: Operation process of DBN model.

The matrix representing the weighted graph $G = (V, E, w)$ is called the weighted adjacency matrix, and is set as W . Firstly, the Laplacian matrix of graphs is obtained by defining the convolution formula of graphs with the theory of graphs. The traditional Fourier transform, convolution analogy to Fourier transform and convolution on the graph signal get the following graph convolution product definition:

$$y = U g_{\theta}(\Lambda) U^T x \quad (6)$$

Where x is the input graph signal and $U^T x$ is the matrix form of Fourier transform of graph signal x , where U is the characteristic vector of graph Laplacian matrix, and $\Lambda = \text{diag}(l_0, l_{n-1}) \in R^{n \times n}$, $g_{\theta}(\Lambda) = \text{diag}(\theta)$ and $\theta \in R^n$ are a Fourier coefficient vector.

Self-encoder is an unsupervised learning method, which is mainly used in data dimensionality reduction and feature extraction. AE consists of an encoder and a decoder, and its calculation flow can be expressed as follows:

$$h^1 = f_1(w^1x + b^1) \quad (7)$$

$$y = f_2(w^2h^1 + b^2) \quad (8)$$

Where x is the input of the network, w^1, b^1 is the weight and bias of the encoder, w^2, b^2 is the weight and bias of the decoder, f_1, f_2 is the nonlinear change, and y is the reconstruction input, and the mean square error function is usually used to compare the values of x, y , and finally h^1 is used as the encoding result of the encoder.

3.3 Interactive Optimization of Traditional Art Design Based on Image Enhancement

The concept of HCI can be simply described as the interaction between human and machine. The degree of human interaction with machines is both simple and complex. Therefore, HCI technology can be roughly divided into physical layer, cognitive level and emotional level. During the enhancement process, one of these sub-networks is selected to enhance the current image according to the state of the current output image, and this method is iterated until the maximum number of enhancement steps is reached. As a result of computer-aided, it is increasingly difficult for the traditional single design effect to adapt to the development trend of art design, and the audience needs more exciting and diverse visual and auditory experiences. This will undoubtedly put forward higher requirements for the design level of relevant designers, and relevant designers also need to strengthen exchanges and communication with the audience, so as to design works that are more in line with the audience's interests. The interactive experience generation mode of art design is shown in Figure 3.

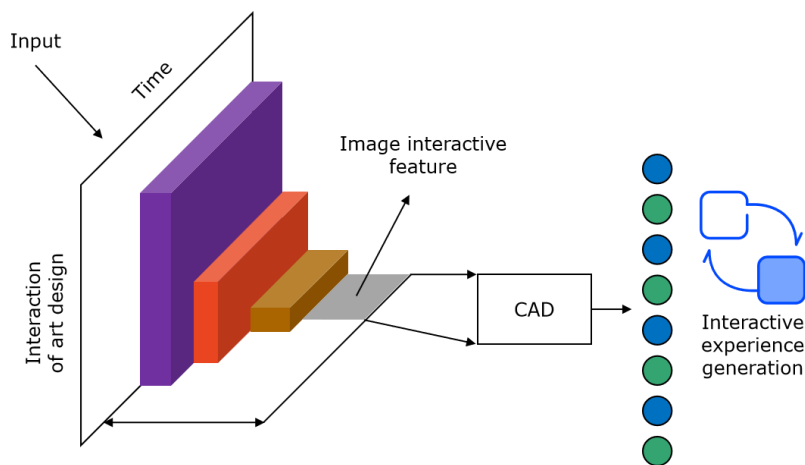

Figure 3: Interactive experience generation mode of art design.

Before thinning the difference feature matrix, a series of preprocessing are carried out, including sample-by-sample average removal and normalization, that is, for the difference matrix of each image sample, the difference average value of the sample is subtracted and the difference value data of different samples are normalized to the same range. Most general optimization algorithms are easy to fall into local minima, so that task-specific optimal solutions cannot be found. Sparse data processing is beneficial to the image processing of human visual system, which can make

DBN better simulate the visual system and extract more essential features, so as to better realize image recognition.

According to the established image feature acquisition model, the art image enhancement process can be described as follows:

$$f(x) \approx f_k(x) = \sum_y [g_k(y) - n_k(y)] h_k^{BP}(m_k'(x) - y) \quad (9)$$

g_k represents the low resolution (LR) image of the k th frame, and $g_k(y)$ represents the gray value of the LR image at the position $y = [s, t]^T$; f represents the ideal high resolution (HR) image, and $f(x)$ represents the gray value of the ideal HR image at the position $x = [u, v]^T$; f_k represents the HR image obtained from g_k solution; n_k is the superimposed noise defined on g_k ; h_k^{BP} can be considered as the approximation of the inverse process of the point spread function; m_k' represents the pixel mapping relationship from HR image f to LR image g_k .

After sparse coding, the dictionary of high LR image blocks is expressed as follows:

$$D_h = \arg \min_{\{D^h, A\}} \|X^h - D^h A\|_2^2 + \lambda \|A\|_1 \quad (10)$$

$$D_l = \arg \min_{\{D^l, A\}} \|Y^l - D^l A\|_2^2 + \lambda \|A\|_1 \quad (11)$$

Where $X^h = \{x_1, x_2, \dots, x_n\}$ is HR image block set, $Y^l = \{y_1, y_2, \dots, y_n\}$ is LR image block set, and A is sparse matrix.

The edge reconstructed image I_e and the detail reconstructed image I_d can be fused by using the perceptual image W_d , so as to obtain the final super-resolution image I_h . The fusion process can be represented by the following formula:

$$I_h(x) = \begin{cases} W_d(x) \cdot I_d(x) + [1 - W_d(x)] \cdot I_e(x), & x \in \bigcup_n R_n \\ I_e(x), & x \notin \bigcup_n R_n \end{cases} \quad (12)$$

The interactive experience graph is established in the coordinate system of low-resolution image, so when using the above fusion formula, it is necessary to first convert the interactive experience weight graph into the coordinate system of high-resolution image.

The emotional level is put forward in a relatively short time, mainly by changing users' attitudes and emotions to increase users' stickiness. Due to technical and ethical problems, emotional man-machine technology still needs continuous exploration and development. Designers can use related computer software to create roaming demonstration animation, so that the actual scene can be simulated realistically, and the audience can browse the spatial effect from different perspectives through this demonstration mode, making people immersive. This demonstration mode is unimaginable in traditional art design, and designers can insert various lights and sounds in the demonstration process to improve the demonstration effect. For the more complex task of low-light image enhancement, based on the idea of optimization-driven DL, a task-embedded coordinate updating method is constructed to accurately estimate the illumination layer and

reflection layer, so as to finally realize outstanding brightness enhancement and detail texture restoration.

4 TEST RESULTS AND ANALYSIS

AI and art design have confronted each other and gradually merged, and they have been continuously applied in the field of interactive art design, and interaction has been highlighted as a key point. Aiming at the inverse problem of image enhancement, a new optimization-driven DL framework is constructed, that is, the DL algorithm based on optimization expansion. On the one hand, it overcomes the shortcomings of the existing model-driven method, such as complex calculation and lack of performance guarantee, on the other hand, it makes up for the unreliability of the DL method. Under the guidance of optimization theory, a new algorithm with both theory and performance guarantee is constructed. Because the superposition process of different distortions is known when constructing the data set, the most suitable loss function can be created according to the real prior, and the enhancement result obtained in this way should be the best enhancement result in theory, that is, the upper limit of enhancement performance. Figure 4 shows the results of precision tests on various image enhancement algorithms.

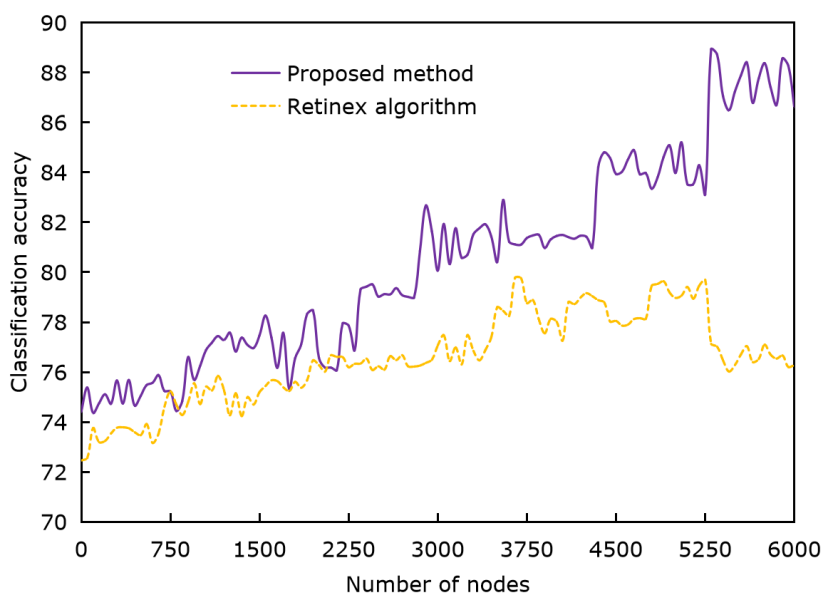

Figure 4: Accuracy test of different image enhancement algorithms.

The image enhancement algorithm of CAD art design proposed in this article can effectively solve the problems of unclear and stereoscopic images on the premise of ensuring image clarity. Compared with Retinex algorithm, its accuracy is improved by more than 15%. The algorithm can estimate the corresponding input graphics only by using a single image, thus effectively enhancing the image. The final enhancement effect depends largely on the selection of input graphics.

The extraction of information is selected from the images of each layer, and the remaining information is directly transmitted to the next layer. Assuming that the information extracted in the first layer is the color of a large color block with great color difference in the image, the color extracted in the following base layer will gradually deepen and the details will become deeper and deeper. Figure 5 is a comparison of F1 values obtained by different algorithms.

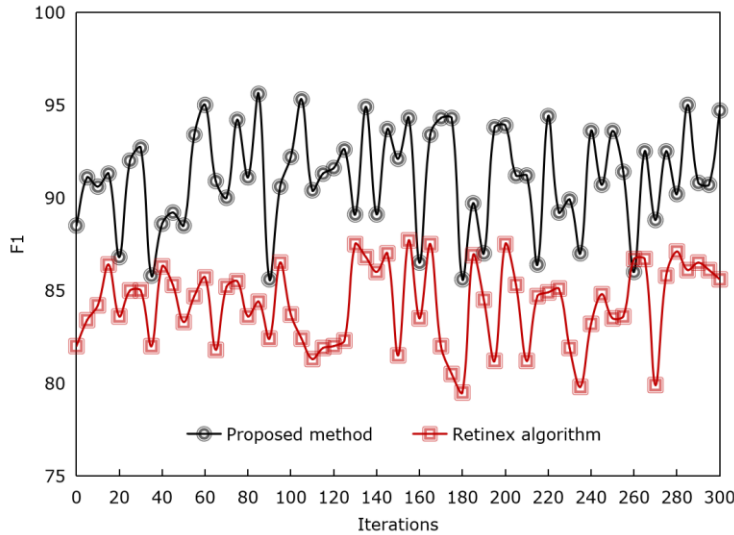

Figure 5: Comparison of F1 values of several algorithms.

For the color enhancement model, the test results show that the perceptual loss function can slightly improve some commonly used quantitative indicators, but there is no obvious improvement subjectively. Confrontation training can change the overall color style, but it is also easy to cause local color distortion. For the hybrid multi-distortion enhancement model, the recognition rate loss function can effectively improve the recognition accuracy in the license plate recognition task, but it will also cause the subjective quality of the image to decline. The test of image processing errors of different algorithms is shown in Figure 6.

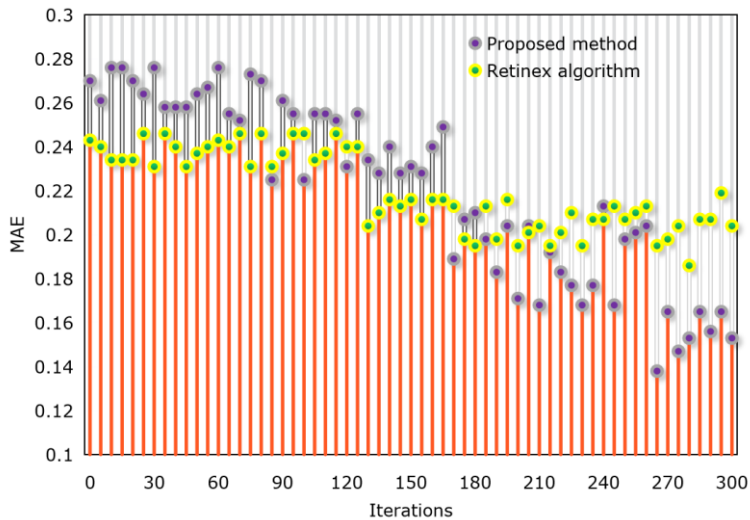

Figure 6: Image processing errors of different algorithms.

For the background estimation part, the depth model with descriptive data characteristics derived from the model is used to realize more accurate background image estimation, and denoising training data is used to simulate the estimation of clear images in this part during the training process. In the process of background estimation, it is actually to optimize the image after

removing some rain lines. The optimization process is understood as denoising, that is, to realize more accurate estimation of the background by expressing the denoising process. Figure 7 shows the audience's evaluation of the interactive experience of traditional design graphics.

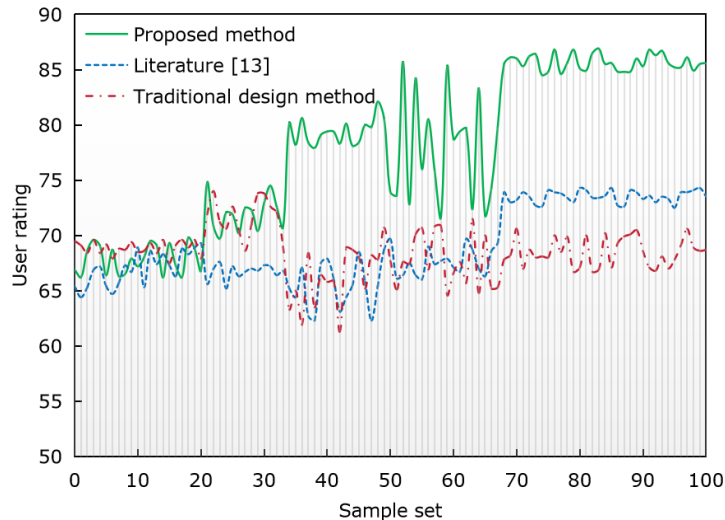

Figure 7: Rating of the viewer's interactive experience with art and design images.

Experiments show that this method can well preserve the local structural information in the image; Contrast and stereoscopic enhancement; It embodies the characteristics of optimal scale selection. The simulation accuracy and appreciation of this system have achieved good results, which can enhance the interaction between traditional art design and appreciation.

5 CONCLUSIONS

HCI art represented by interactive design is a new artistic expression, which can not only realize normal HCI, but also bring good artistic experience to users through various senses and psychology of human body. In order to enhance the interactive experience of art design process, this article proposes an art design image enhancement algorithm based on DNN driven by AI, which regards the solution of the deep network as the descending direction to speed up the search for the target solution. The results show that the simulation accuracy and appreciation of this system have achieved good results, which can enhance the interaction between traditional art design and appreciation. There is a lot of work on network complexity optimization in high-level visual tasks, but there is still little research on this aspect in the field of image enhancement at present. Effective complexity optimization will expand the application scope of image enhancement based on deep network. In the future work, we will continue to explore the relationship between optimization theory and DL. Using more solid and flexible optimization theory, the deep network structure with stronger representation ability is fused.

Tanqiu Wang, <https://orcid.org/0009-0001-9465-742X>

Dan Wu, <https://orcid.org/0009-0001-8232-648X>

REFERENCES

- [1] Canet, S.-M.; Guljajeva, V.: Dream painter: exploring creative possibilities of ai-aided speech-to-image synthesis in the interactive art context, Proceedings of the ACM on

- Computer Graphics and Interactive Techniques, 5(4), 2022, 1-11. <https://doi.org/10.1145/3533386>
- [2] Cheng, X.: Interactive design of museum display system in the context of new media, Highlights in Art and Design, 3(1), 2023, 15-18. <https://doi.org/10.54097/hiaad.v3i1.9160>
- [3] Chenyi, Q.; Choi, J.: Human gestures and five elements with kinect-based interactive installation in modern new media art, TECHART: Journal of Arts and Imaging Science, 8(3), 2021, 15-19. <https://doi.org/10.15323/techart.2021.8.8.3.15>
- [4] Fan, X.; Li, J.: Artificial intelligence-driven interactive learning methods for enhancing art and design education in higher institutions, Applied Artificial Intelligence, 37(1), 2023, 2225907. <https://doi.org/10.1080/08839514.2023.2225907>
- [5] Frutiger, J.; Cignitti, S.; Abildskov, J.: Computer-aided molecular product-process design under property uncertainties - A Monte Carlo based optimization strategy, Computers & Chemical Engineering, 122(3), 2019, 247-257. <https://doi.org/10.1016/j.compchemeng.2018.08.021>
- [6] Gao, S.-B.; Zhang, M.; Zhao, Q.; Zhang, X.-S.; Li, Y.-J.: Underwater image enhancement using adaptive retinal mechanisms, IEEE Transactions on Image Processing, 28(11), 2019, 5580-5595. <https://doi.org/10.1109/TIP.2019.2919947>
- [7] Jeon, M.: Hands-on real-time interactive art using particle system, TECHART: Journal of Arts and Imaging Science, 8(4), 2021, 5-8. <https://doi.org/10.15323/techart.2021.11.8.4.5>
- [8] Jin, H.; Yang, J.: Using Computer-aided design software in teaching environmental art design, Computer-Aided Design and Applications, 19(1), 2021, 173-183. <https://doi.org/10.14733/cadaps.2022.S1.173-183>
- [9] Li, L.: Digital art design system based on big data technology and interactive virtual technology, IEEE Consumer Electronics Magazine, 12(2), 2021, 49-55. <https://doi.org/10.1109/MCE.2021.3133267>
- [10] Pelliccia, L.; Bojko, M.; Prielipp, R.: Applicability of 3D-factory simulation software for computer-aided participatory design for industrial workplaces and processes, Procedia CIRP, 99(1), 2021, 122-126. <https://doi.org/10.1016/j.procir.2021.03.019>
- [11] Stark, L.; Crawford, K.: The work of art in the age of artificial intelligence: What artists can teach us about the ethics of data practice, Surveillance & Society, 17(3/4), 2019, 442-455. <https://doi.org/10.24908/ss.v17i3/4.10821>
- [12] Wang, X.; Cai, L.: Application of artificial intelligence in 6G internet of things communication in interactive installation art, International Journal of Grid and Utility Computing, 13(2-3), 2022, 195-203. <https://doi.org/10.1504/IJGUC.2022.124401>
- [13] Yuan, G.; Li, J.; Liu, X.; Yang, Z.: Weakly supervised road network extraction for remote sensing image-based scribble annotation and adversarial learning, Journal of King Saud University-Computer and Information Sciences, 34(9), 2022, 7184-7199. <https://doi.org/10.1016/j.jksuci.2022.05.020>
- [14] Yuan, Q.; Wang, R.; Pan, Z.: A survey on human-computer interaction in spatial augmented reality, Journal of Computer-Aided Design & Computer Graphics, 33(3), 321-332. <https://doi.org/10.3724/SP.J.1089.2021.18445>
- [15] Zhang, B.: New media interactive design visualization system based on artificial intelligence technology, International Journal of Information Technologies and Systems Approach (IJITSA), 16(3), 2023, 1-14. <https://doi.org/10.4018/IJITSA.326053>
- [16] Zhang, W.; Ren, D.; Legrady, G.: Cangjie's poetry: an interactive art experience of a semantic human-machine reality, Proceedings of the ACM on Computer Graphics and Interactive Techniques, 4(2), 2021, 1-9. <https://doi.org/10.1145/3465619>